

200# W.O.G. GATE VALVE



SPECIALTY VALVE & FITTING Co. 7551 East Rosecrans Avenue • Paramount, CA 90723
 To Order, Call: (562) 602-1400 • (800) 421-2219 or FAX: (562) 630-7700

SPECIFICATIONS:

FIG. 33GT6

SAM-FLOW®

- Investment Casting
- Solid Wedge Disc
- Hydrostatic Test:
Shell: 300 PSI
Seat: 220 PSI
- Screwed-In Bonnet
- Hand Wheel Operation
- Non-rising Stem
- 200 PSI at 350° F



DIMENSIONS

Size	A	H (Open)	L	W	Cv Rate GPM	Net Wt.
1/2	5/8	3 1/2	2 3/16	2 3/4	17.6	.88
3/4	13/16	3 13/16	2 3/8	2 3/4	32	1.10
1	1	4 1/4	2 5/8	3 3/16	54	1.50
1 1/4	1 1/4	4 3/4	3	3 3/16	97	2.40
1 1/2	1 5/8	5 3/4	3 3/8	4	135	3.30
2	2	6 7/16	3 3/4	4 1/2	230	4.60

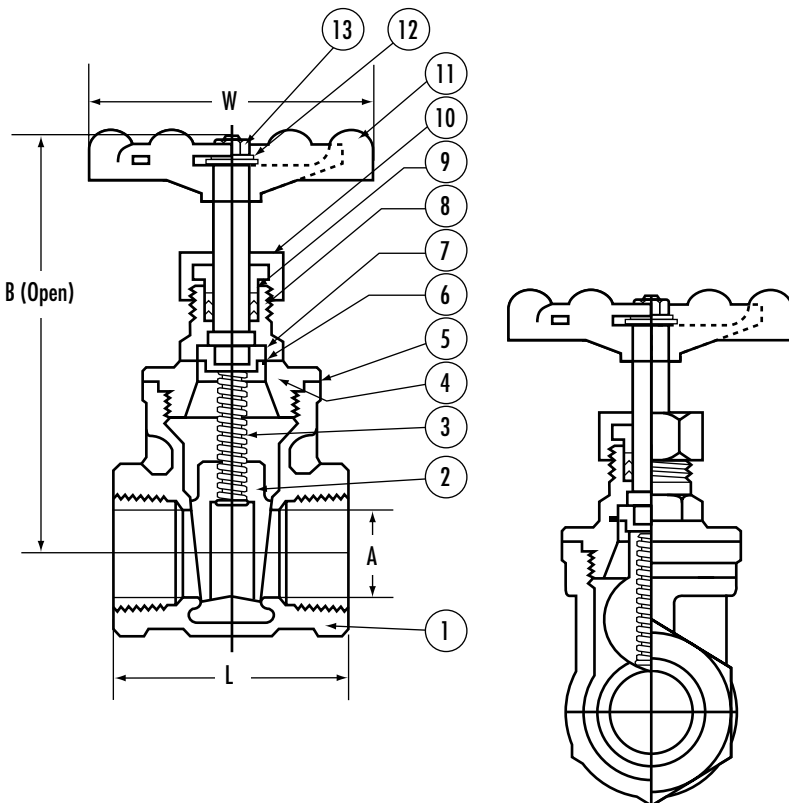

MATERIALS LIST

No.	Part Name	Material
1	Body	ASTM A351 - CF8M
2	Disc	ASTM A351 - CF8M
3	Stem	SS 316
4	Bonnet	ASTM A351 - CF8M
5	Gasket Packing	Teflon
6	Stop Ring	SS 304
7	Stem Holder	SS 316
8	Stem Packing	Teflon
9	Gland	SS 304
10	Gland Nut	SS 316
11	Handwheel	DUC Iron
12	H/W Washer	SS 304
13	H/W Nut	SS 304